



POLARIS+

INDUSTRIAL AIR COMPRESSORS



Delivering What Matters Most

The question isn't, "Which compressor can do the job?" Many can perform that basic function. More important is knowing which compressor works reliably longer, even in the most demanding environments. Knowing which saves money by using energy more efficiently and minimizes downtime and the hassle of emergency repairs and ongoing maintenance.

The question is "Which compressor delivers what matters most?"

When you ask the right question, the answer is clear: FS-Elliott's Polaris+® compressors not only do the job, they deliver the high quality, efficiency, and ease of operation that make any job more successful.



Why Centrifugal?

Efficient aerodynamics make centrifugal compressors ideal for a variety of industrial applications. Centrifugal compressors produce pressure by transferring energy from a rotating impeller to the air. Capacity can be controlled by adjusting the inlet guide vanes—closed to reduce and open to increase flow.

Polaris+ centrifugal compressors feature a simple, effective design that outperforms other compressors in delivering trouble-free operation and the lowest cost of ownership. Polaris+ owners enjoy:

- **Certified ISO 8573-1 Class 0 oil-free air** for purity that meets exacting standards.
- **Low maintenance** with no wearing parts that require regular change-out, the need for periodic and expensive airend replacement is eliminated.
- **Low-to-no vibration** without any special foundation required.
- **Superior control** through a variety of Regulus® controller system options.
- **Excellent reliability** over extended periods with minimal maintenance.

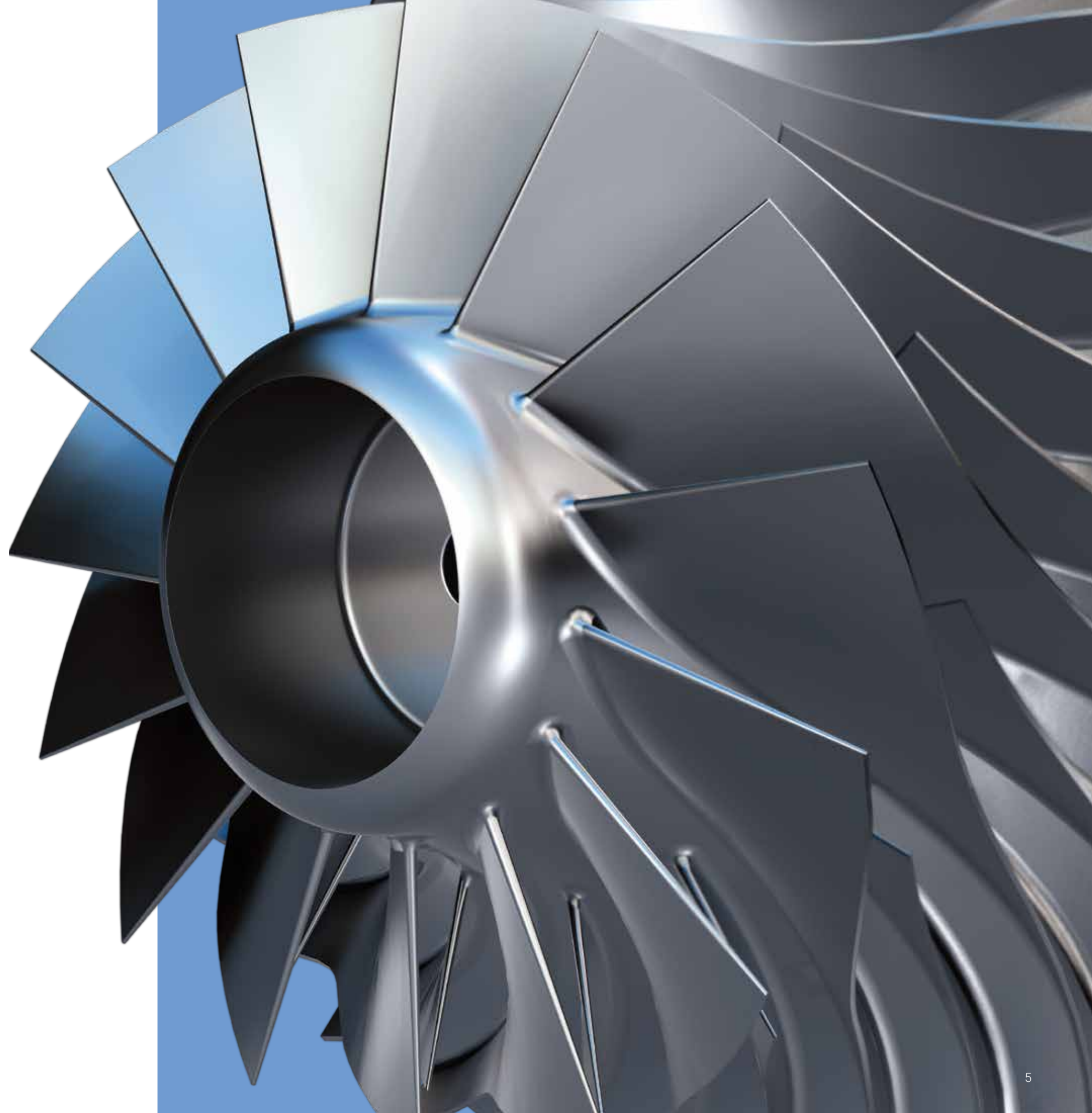

Compression Flow Process

- 1** Ambient air enters the first stage through the inlet control device.
- 2** The first-stage impeller accelerates the air. A radial diffuser converts the air's velocity into pressure before the air enters the scroll casing.
- 3** The air is conducted through interstage piping into the first intercooler.
- 4** The cooled air then flows into the second-stage inlet piping.
- 5** The compression process is repeated as the air passes through the second stage impeller, diffuser, and scroll casing and then into the second intercooler.
- 6** Air from the second intercooler moves through a third impeller, diffuser, and scroll casing.
- 7** Air is discharged into the aftercooler and air system.

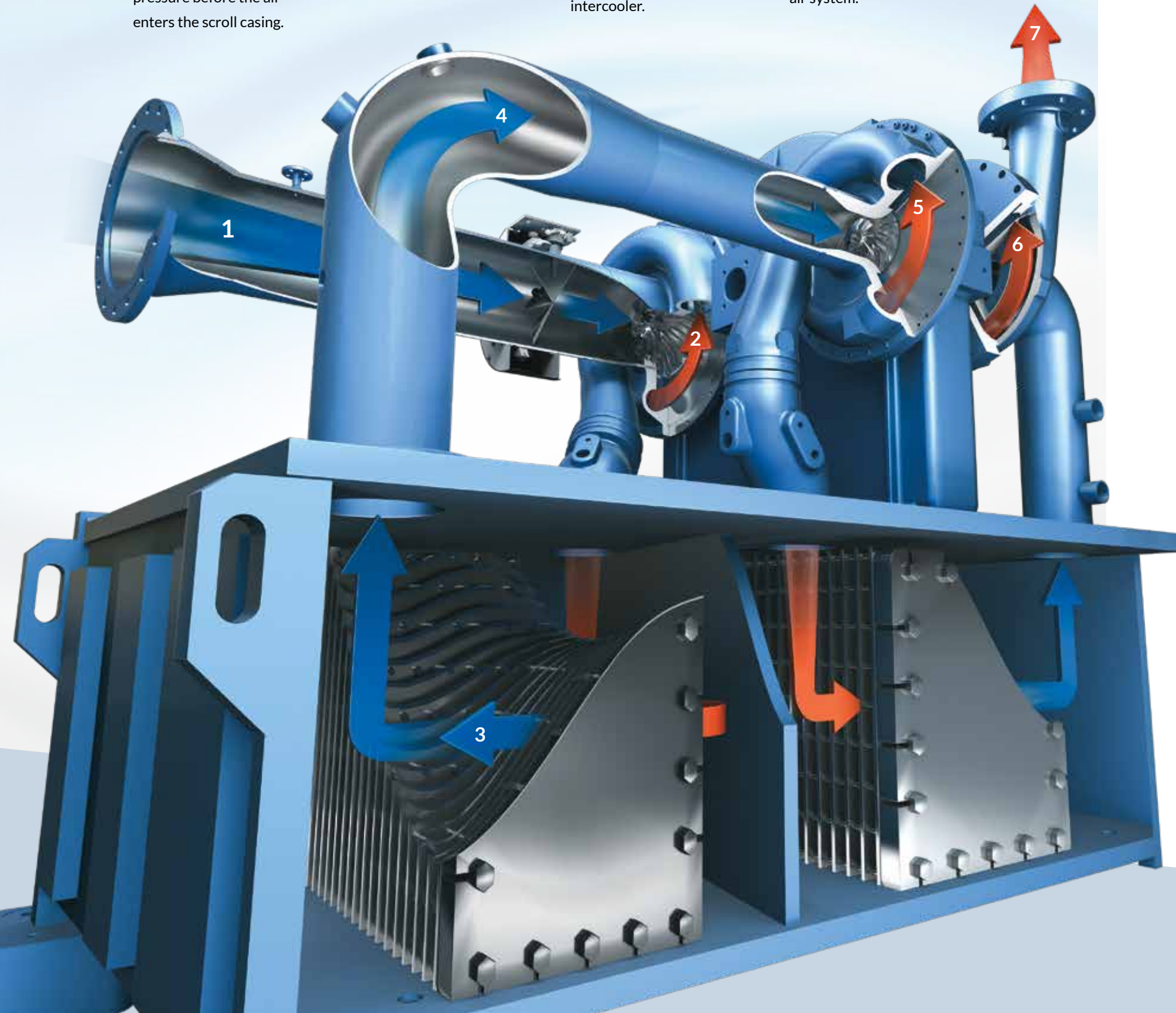

Highest Quality

Delivering the most reliable, oil-free air in the industry does not happen by chance: it is the result of a rigorous focus on quality from the inside out.

FS-Elliott is committed to building products that will exceed our customers' high standards. At the heart of the Polaris+ compressor is a technologically advanced, yet beautifully simple, aerodynamic design that builds on the flawless reliability of our custom-engineered PAP Plus® product line.

Every unit we manufacture is subject to strict quality control at our ISO 9001-certified manufacturing facility to ensure consistent reliability from commissioning through years of demanding use.



For a detailed animation of this compressor, visit us online:

WWW.FS-ELLIOTT.COM

Energy Savings

Any compressor can supply pressurized air. What sets Polaris+ compressors apart is the advanced aerodynamic designs and control systems that enable them to deliver reliable compressed air while minimizing energy and maintenance costs.

Aerodynamic Design and Materials

Polaris+ compressors combine optimized aerodynamic stage matching with intercooler efficiencies to reduce power requirements. Stainless steel, 5-axis machined impellers resist corrosion leading to longer product life and provide the highest efficiency in its class. Each impeller features a backward-leaning design that can be precisely controlled to optimize both airflow and air compression. To perfect the aerodynamics of your machine, impellers are custom designed to your specific applications and site conditions.



Mechanically Superior Bearings

Polaris+ compressors feature mechanically superior bearings that require less oil consumption and enable operators to reduce power requirements.



Adjustable Inlet Guide Vane

By controlling the amount of air being compressed (and consequently the power consumed), inlet guide vanes efficiently adjust to plant conditions and load variations to conserve energy.

Discover the savings a centrifugal compressor will bring to your facility using our easy, online tool:

WWW.AIRCOMPARE.FS-ELLIOTT.COM



Proactive Control System

The advanced Regulus Control System, standard on every model, offers flexible control to efficiently manage plant load and maximize energy savings.

- **Ambient Compensation Control** automatically adjusts the compressor surge control line based on changes in ambient conditions, allowing operators to reduce waste by maximizing turndown and minimizing bypass air.
- **Integrated Compressor Control** adjusts performance by assigning lead and lag machines according to system demand. This eliminates excessive air production, minimizes bypass air, and reduces energy consumption.
- **Pressure Band Optimization** assists in avoiding unnecessary discharge air by continually regulating compressor output based on the minimum pressure required to meet system demand.

Integrated Compressor Control

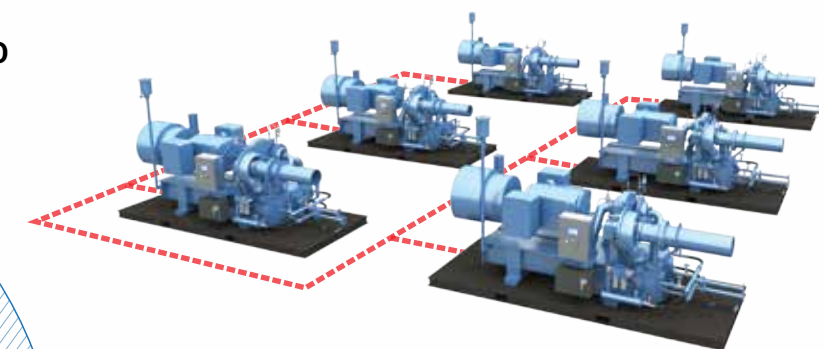

Efficiency Improvements with ACC & PBO

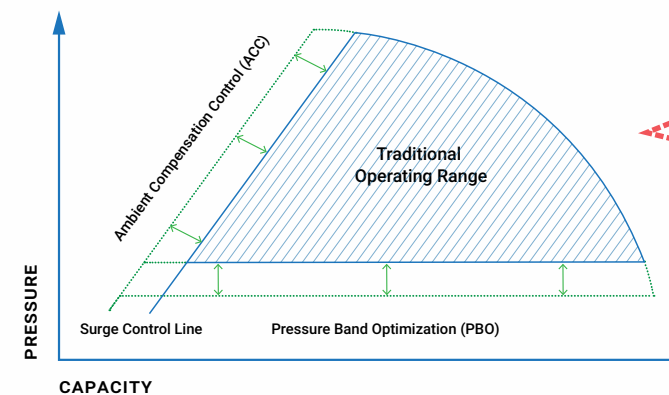



Ease of Ownership

No matter how well a compressor performs, if it's difficult to install, commission, and maintain, why own it? Polaris+ compressors are built to be easy to own and operate, year after year.

Installation Ease

By packaging key components and accessories, including the aftercooler, water manifold, and lube system, Polaris+ compressors reduce site preparation time and costs, making installation easier.

Operation Ease

The ergonomically designed 9" full touch-screen control display comes standard on all Polaris+ compressors, and brings compressor control into the modern era. Navigating the control system is an intuitive experience that simulates application-based computing.

Maintenance Ease

Polaris+ compressors combine several features that allow them to operate reliably for extended periods with minimal maintenance.

- **Horizontally-split gear case and internal components** are integral features of the only truly field-serviceable gear box in the industry.
- **Engineered coatings designed for extreme conditions** provide extended service life of internal and external surfaces, reduced maintenance, and corrosion prevention.
- **Straight-through intercooler tube** accommodates periodic cleaning, rather than replacement.
- **FS-Elliott brand fluids** last longer and provide excellent wear protection. By minimizing harmful build-up, they also ensure longer equipment operating cycles.
- **Full-capacity auxiliary oil pump** continues normal, safe operation in the event of a main oil pump failure.
- **Trained local distribution network** offers expert repair and maintenance services on demand 24/7/365.

Product Features

The quality of what goes into Polaris+ compressors is essential to the quality of what comes out. A range of advanced features ensures efficient, trouble-free performance over years of demanding use.

- **R1000 Control System**, featuring a 9-inch full touch-screen display, introduces several new control modes to provide increased energy efficiency.
- **Engineered coatings** that deliver extended service life, reduce maintenance, and prevent corrosion.
- **Mechanically superior bearings** that result in improved stability, require less oil consumption, and reduce power requirements.
- **Dual carbon ring seals** keep the lubricant in the gearbox, ensuring it does not reach the compressed air stream.
- **Consolidated package upgrades**, providing increased package flexibility, additional future upgrade consideration, and extended product life.
- **Advanced aerodynamic staging** that reduces power consumption.
- **Simple, practical design** increases reliability and decreases downtime by limiting rotating and wearing parts and accommodating quick field maintenance.

To see how a Polaris+ compressor operates, visit us online:

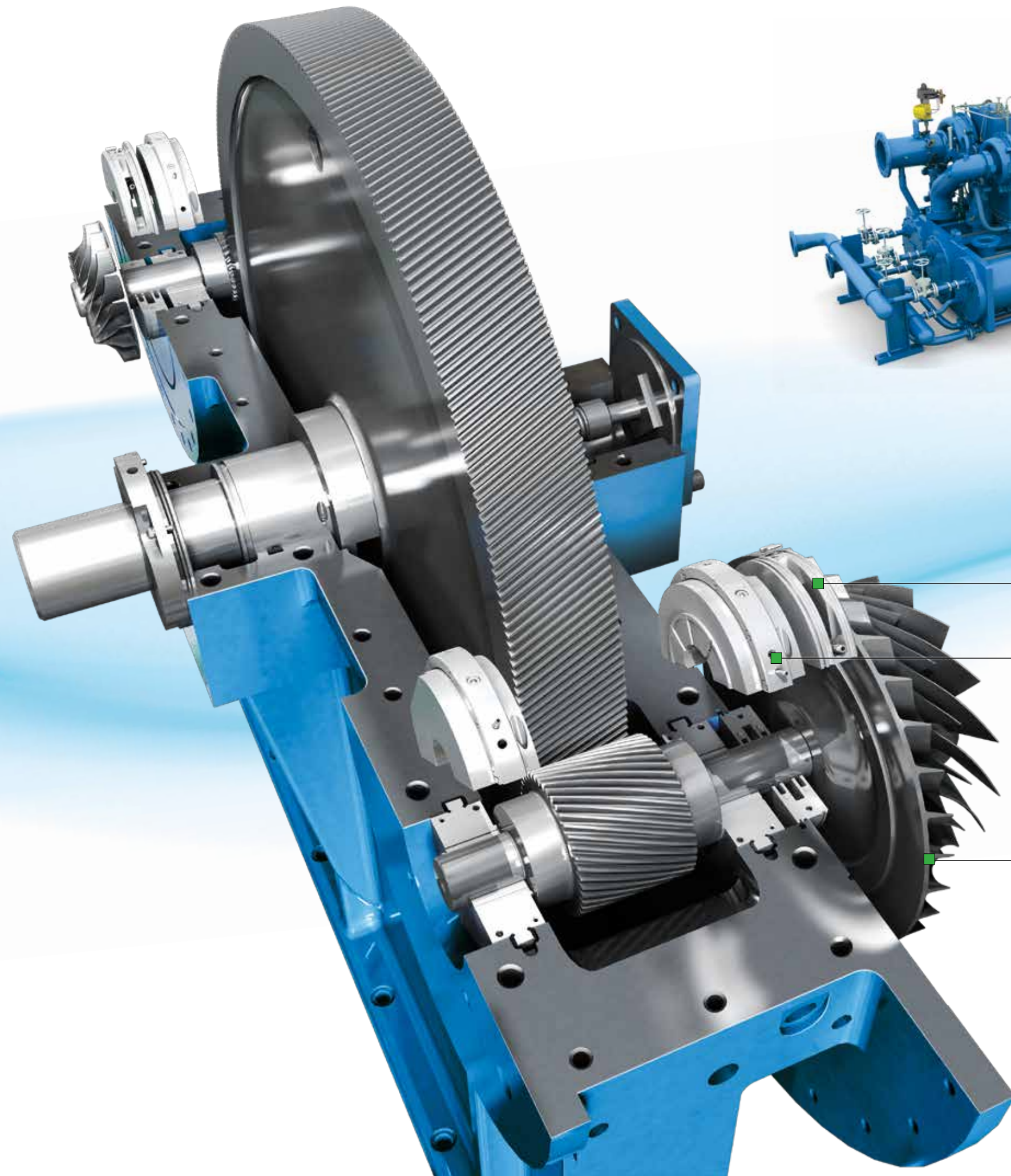

Horizontally Split Design

The exclusive split bearing and seal design are integral features of the only truly field-serviceable gearbox in the industry.



Stainless steel, 5-axis machined impeller optimizes airflow and provides highly-efficient air compression.

Weights, Dimensions & Ranges

Polaris+ compressors combine over 50 years of operational and design experience in an extremely reliable, energy-efficient, cost-effective package. They suit a broad range of applications, with models ranging from 250 hp to 2,600 hp in two- and three-stage configurations that deliver up to 14.9 BARG (216 psig) discharge pressure.”

Polaris+ Model	Overall Dimensions						Approximate Weight*	
	A*		B*		C*		lb.	kg
	in.	mm	in.	mm	in.	mm		
P300+	115	2910	101	2568	72	1832	10000	4550
P400+	143	3632	75	1905	81	2057	14500	6575
P500+	125	3175	85	2160	85	2160	16000	7260
P600+	159	4040	87	2208	88	2238	13500	6222
P700+	181	4597	92	2337	87	2210	28800	13063

* Value may vary with motor rating and type

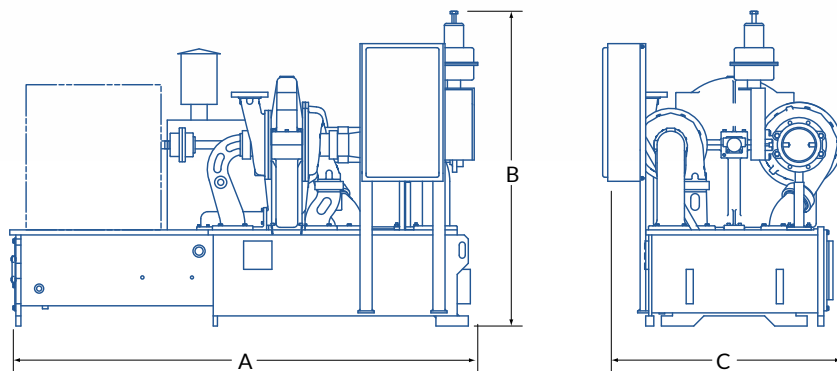

Discharge Pressure
14.9 BARG (216 PSIG)

Performance may vary based on actual site conditions. Consult your authorized FS-Elliott distributor for more information.

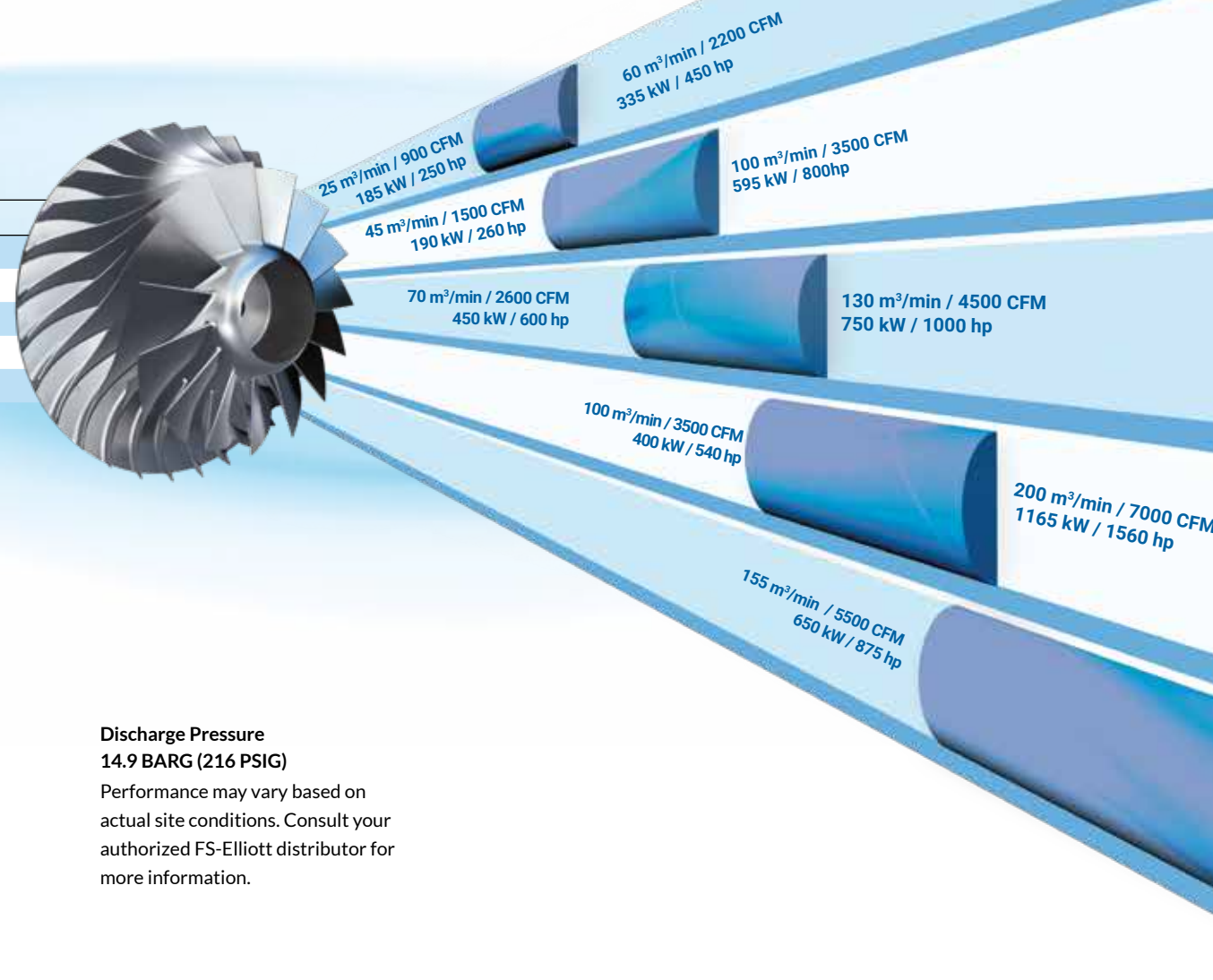

P300+



P400+



P500+



P600+



P700+

Options & Accessories



Sound Enclosures

Modular enclosures accommodate installation sites that have special acoustic requirements. A rigid base frame provides a stable foundation, while side and roof panels are removable for easy access during routine maintenance and handling.



Motor Starters

Choose from a full line of motor starters to suit your needs. Certain models include an option to mount the starter on the unit.



Regulus Control Systems

The standard 9" full touch-screen display allows you to easily monitor and manage the performance of one or multiple compressors, at the unit or remotely, to meet air demands while maximizing energy savings.



Dual Oil Filters With Integral Transfer Valve

When continuous operation is essential and shutdowns for routine maintenance are unacceptable, opt for the dual filter and transfer valve configuration. It allows the compressor to continue to operate while switching smoothly from one filter element to the other.



FSE Brand OEM Lubricants

Our exclusive line of lubricants includes FSE-TurboCool™, a superior full synthetic fluid specifically designed for centrifugal compressors, minimizing harmful build-up and maximizing equipment operating cycles. Exclusive use of FSE brand OEM lubricants is included in the preventive maintenance guidelines provided as part of SteadiAIR® 5, an extended warranty program adding peace of mind and reducing the long-term cost of ownership.



Global Coverage, Local Support

FS-Elliott compressors are designed with field maintenance and service in mind, allowing your plant personnel to perform regular inspection and maintenance or choose to work with a local factory trained and certified distributor service team. Backed by over 50 years of centrifugal compressor expertise, our global network of personnel and facilities are ready to address your service needs quickly and professionally. From initial design and installation to timely upgrades in step with your evolving needs, we are committed to keeping your vital operations productive, optimized, and reliable.



Efficient Installation and Start-Up

Working with our distributors, we tailor installation and start-up services to meet your needs. From providing quality assistance to your commissioning team to delivering total turnkey installation, we will help get your machine up and running quickly and efficiently.



Remote Technical Service

FS-Elliott and our global distribution network provide the first line of support with experienced engineers and technicians who are equipped to offer troubleshooting and operation/maintenance advice remotely.



Timely Accurate Repairs

Our compressors are designed for complete field servicing. FS-Elliott's factory authorized distributor service network is available to perform a variety of repairs at your facility from a simple oil change to a complete overhaul.



Essential Preventive Maintenance Made Easier

Polaris+ compressors include key features that ensure reliable operation over extended periods with minimal maintenance:

- Inherently low vibration
- No rubbing or direct wearing parts
- Optimum clearances between rotating and stationary parts
- No oscillating load
- Integrated package to simplify installation and ongoing use

Even with a reliable design, preventive maintenance is key to avoiding unexpected shutdowns and production interruptions. FS-Elliott and our distribution network will act as your preventive maintenance partners throughout the life of your machine.

Ask your authorized FS-Elliott Channel Partner or Representative about our SteadiAIR®5 extended warranty program.



Auxiliary Upgrades

FS-Elliott offers a range of control system upgrades and associated equipment upgrades, such as inlet guide vanes, to ensure the most efficient compressed air supply regardless of your system's age.



OEM Equipment Overhaul

The airend overhaul program will provide you with a completely revamped compressor core, refurbished back to OEM specifications.



Training

We offer a wide range of operator and maintenance training programs, including standard, self-contained packages and customized sessions to fit your needs. Training can be delivered at your facility or one of ours.



24/7/365 Parts and Service Availability

Our global service network offers round-the-clock emergency service 365-days a year. We also maintain an extensive inventory to give you immediate access to quality OEM service parts.



Extended Value Through Machinery Modernization (Upgrades/Rerates)

Rerating an existing compressor is an efficient option to meet the changing demands of your compressed air system. By implementing design innovations and upgrades to match current needs, you can improve reliability and reduce life-cycle costs.



Headquarters—Export, Pennsylvania, USA

Basingstoke, United Kingdom
Houston, Texas, USA
Jubail, Kingdom of Saudi Arabia
Köngen, Germany
Kuala Lumpur, Malaysia
Los Angeles, California, USA
Pune, India
Shanghai, China
Taipei, Taiwan
Tangerang, Indonesia

Building on a 50-year tradition of excellence in compressor design and manufacturing, FS-Elliott brings our customers the resources of a global industry leader along with the convenience and responsiveness of local sales and service. Thousands of reliable, hard-working FS-Elliott compressors are installed worldwide.

FS-Elliott Co., LLC

5710 Mellon Road
Export, PA 15632-8948, USA
+1.724.387.3200 tel
+1.724.387.3270 fax
info@fs-elliott.com email
www.fs-elliott.com

Represented by:



ISO 9001- certified
for the design and
manufacture of
centrifugal compressors.

FS-Elliott Co., LLC reserves the right to modify the design or construction of the equipment described in this brochure and to furnish it, as altered, without further reference to the illustrations or information contained herein.

Bulletin FSP82-719